

The formula is based on a UK specification 998cc British Leyland Mini, **no other cars/bodyshells permitted to race alongside ORCi Ministox. No competition, sports, performance, Cooper or Cooper S parts are permitted unless expressly permitted within these specifications. *IF YOU DO NOT UNDERSTAND ANY PART OF THESE TECHNICAL SPECIFICATIONS, IT IS YOUR RESPONSIBILITY TO ENQUIRE, NOT ASSUME IT IS AN EXCUSE FOR NON-CONFORMITY.***

VIOLATIONS

When referring to these specifications the principle will always be: unless permission is specifically granted to make modifications, or any variation, nothing can be done to alter or change in any way the standard parts. **Unless these rules state you can do it, you CANNOT DO IT.**

Violations or any refusal of a scrutineering check will result in an immediate suspension of all racing facilities. All car and engine specifications will be taken from the Technical Service Data book as published by Glass's Guide Service Limited or the relevant Haynes Manual. Technical queries can be addressed to, ORCi Limited, Technical Committee, P O Box 530, Hoddesdon, EN11 1RR or email to secretary@orci.co.uk.

No newly constructed car is permitted to race without being technically scrutineered by an appointed ORCi Technical, in advance of its first race meeting.

Drivers are reminded that technical checks can be carried out at any time. If parts are suspected of being illegal you must leave them with the promotion if you do not agree. If you refuse it will automatically make the parts illegal. **It is the responsibility of the driver to prove to the ORCi that the part is legal by the way of written proof of where the part originated. This must be done within seven days, otherwise the part(s) in question will be deemed to be illegal and will result in immediate suspension from racing and referral for disciplinary action.**

1. DRIVER REQUIREMENTS

- The minimum age is 11 years old and all drivers will end on the day before their 16th birthday.
- However, a driver aged from 11-12 years may only race under the watchful eye of their promotion, with restricted bookings, until such time as the driver is confident enough to compete fully.
- A copy of the child's birth certificate must accompany their application for a licence.
- **New applicants are required to complete a multiple choice written test and a basic driving skills test before a licence will be issued. This is chargeable at £50 and must be arranged with your licencing Promotion at the time of application.**
- **New drivers will be deemed to be 'ROOKIE' drivers for their first THREE meetings and must start at the rear of the grid and must paint the boot lid with a black or white cross. The Steward of the Meeting will be empowered to ask a driver to remove the cross once they feel that a reasonable level of confidence has been achieved. If the new driver has previous experience in a similar Junior Class, the licencing Promoter may grant the driver a grading status and in such cases would not be classed as 'ROOKIE'.**
- **Rookie drivers must only race at their home Promotion until they are considered competent enough to compete fully. Permission must be granted for Rookie drivers to compete at tracks other than their home Promotion.**
- **Only the registered driver or a responsible adult are allowed to drive the car within the confines of the raceway.**

2. BODYSHELL

- The only bodyshell or panels permitted are original British Leyland/BMC classic Mini Saloon or classic Clubman Saloon. Panels must be original or direct replacement for a classic British Leyland Mini and be of mild steel.
- Door tops maybe cut down as follows: passenger door maximum of 75mm and driver's door 40mm.
- The following items **MUST** be removed from the body shell
 - All lights, fittings bright metal trim, all combustible materials, glass and trimmings.
- The following items **MAYBE** removed from the body shell:
 - Rear parcel shelf, door skins, rear pockets, dashboard bracing, inner wings
- The bonnet and wings maybe welded together to achieve a one piece bonnet. However, the bonnet must sit as originally intended, and not elevated. The bonnet must retain its original front lip. Adequate fixings must be in place to ensure the bonnet cannot come loose during racing.
- The original doors and boot must be welded to the bodyshell.
- If the original floor pan is retained the outer sills must remain as manufactured.
- It is not permitted to blank off the rear light apertures.
- A and B pillars must be retained. From the waistline down structural points on the pillars maybe removed.

- Door skins (in between the upper and lower side rails) maybe replaced by sheet steel up to a maximum of 1.2mm thick.
- **The bulkhead must remain original. Exceptions are permitted for cars built before 1 January 2017 that have parts of the bulkhead removed. However, cars that fall into this category require approval/inspection.** All holes in the bulkhead must be blanked off to create a firewall between the engine and the driver compartment.
- It is permitted to put a name plate across the front and rear window apertures, to a maximum depth of 175mm. No other window apertures are permitted to be blanked off in anyway. Rear side window apertures must remain original at 347mm in height – measured at the vertical centre.

3. INTERNAL STEELWORK

- Steelwork inside the car, rear of the engine compartment is free (with the exception of the Roll cage – rule 4) however this must be constructed from a maximum RHS/SHS steel of 50mm x 30mm, 50mm x 25mm or 40mm x 40mm SHS or RHS, with a maximum wall thickness of 3mm, and must be of equal proportions on both sides of the car.
- The driver's footwell floor pan may be reinforced with steel plate maximum thickness 3mm.
- Any additional gussets must not exceed 80mm x 80mm x 6mm thickness.
- The main floor pan can be retained. However this can also be made good by welding in a minimum of 1.2mm thick mild steel plate from the front footwell/toeboard to the rear footwell/heelboard. The original gearbox tunnel must be retained, to include its entire vertical face/original height and must connect the bulk head to the rear of the car. The cross member under the original front seats maybe removed. The replacement floor pan must be formed/folded to create an inner sill to the original silhouette up to the lower door aperture.
- A sill bar is mandatory if using a non-original floor of the specification noted above, and must run the full distance between the wheels.
- A boot floor must be welded in place, tying in the rear wheel arches and extending out to meet the bodyshell. This maybe original or can also be made good by welding in a minimum of 1mm thick mild steel plate.
- Rear subframe mounting points must remain as manufactured.

4. ROLL CAGE

- **Roll-cage/roof bars/chicken bars and all supports as noted below must be constructed of a minimum size steel of 40mm x 40mm SHS or 38mm tube (minimum 3mm thick) unless stated differently.**

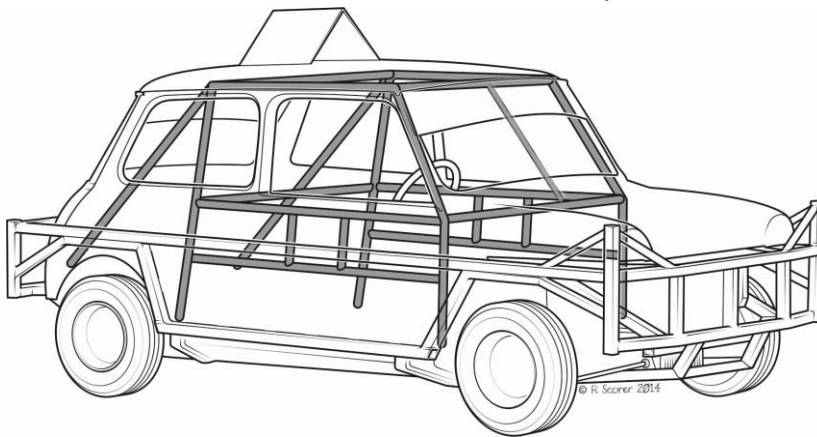

- The rollcage must consist of a screen/front hoop and a hoop behind the driver, with two connecting bars in the roof between these two hoops, plus a centre bar to support the roof plate.
- The maximum distance permitted from the windscreen aperture to the front rollcage hoop is 280mm at the centre.
- The roll cage maybe mounted on the top chassis rails or return directly down to the floor. If mounted on top of the chassis rails it must be supported under the horizontal chassis rail with a vertical mild steel SHS/RHS to the sill.

- If mounted directly to the floor, it must have a steel plate on the base (minimum 100mm square, 3mm thick) welded to the floor, and must also be welded to the internal steelwork, inc. the top chassis rail.
- The rollcage must extend the full internal width of the car but must remain within the confines of the car, and not protrude through the bulkhead.
- To protect the driver's door lower window aperture, there must be a minimum of 25mm x 25mm SHS (3mm thick) steel or 26.9mm steel tube (3mm thick), horizontally between the rollcage A & B pillar at the top of the door. This must also have a minimum of two supports down to the top straight through in the same size steel.
- The roll cage hoop located behind the driver must have two rearward support bars (one each side of the car) running from the **VERY TOP OF THE HOOP (AS SHOWN IN THE DIAGRAM)** downwards to the internal steel work, either in line with the B pillar, angling to the centre of the car, or in a criss/cross fashion. The specification must be a minimum of 40mm x 40mm SHS or 38mm tube (minimum 3mm thick).
- Two chicken bars must be fitted horizontally to the door area on both sides of the car and must extend the full width between the A and B rollcage pillars (a sill bar is not considered to be a chicken bar).
- The chicken bars must have two vertical connecting bars between EACH one and must be symmetrical on both sides of the car. A 3mm plate must be welded to the outside of the chicken bars inside the car on the driver's side. The plate must extend across the full width of the door and must be a minimum of 250mm high.

- A horizontal SHS/RHS steel must be located the full width of the car, between the upper chassis rails behind the driver and at floor level in a similar manner. Additionally, SHS/RHS steel must be located between the upper chassis rails inside the car across the bulkhead.
- A 3mm thick roof plate, on the driver's side of the car, must cover half the roll cage area. This must extend to the front roll cage hoop, rear roll cage hoop, driver's side roof bar and centre support bar, and must be a minimum 750mm in length, not including the rollcage tube.
- The very rear face of the rollcage/roof plate must extend a minimum of 100mm behind the very rear face of the driver's seat.
- A metal upright min size 20mm x 20mm SHS must be welded or bolted in the windscreen aperture, at least one third of the way across from the driver's side. The use of steel mesh is permitted in the front windscreen, but must end half way across on the driver's side only.
- The permitted wheelbase is 2040mm. On the passenger side the tolerance is +/- 25mm, and on the driver's side the tolerance is +/- 5mm.

5. EXTERNAL STEELWORK

- Bumpers/side rails/under rails must be constructed from steel 50mm x 30mm, 50mm x 25mm or 40mm x 40mm SHS or RHS, a wall thickness of 3mm and must be constructed in accordance with the illustration below, to ensure even contact between cars. **All external steelwork must have the full face in a vertical plane.** The steelwork shown as shaded, the maximum specification steel remains the same, although 25mm SHS or equivalent tube as a minimum is permitted.
- All steel must remain hollow i.e. no ballast of any kind is permitted.
- The car must be no wider than 1500mm at its widest point. **The side rails must remain parallel to each other from the front of the car rearwards to the B pillar. The side rails may taper in to the rear bumper.**
- No wheel or tyre is permitted to sit outside the steelwork with the exception of NSF.
- The SHS or RHS must be symmetrical in construction side to side with the exception of driver's area protection as noted above.
- It is permitted to use a secondary piece of SHS or RHS steel to sit under the side rail, above the wheels only (shown as shaded in the illustration). The maximum size steel permitted for this is stated in the first paragraph of rule 5. However the minimum steel is 25mm SHS or equivalent tube.
- A gap between the internal and external side rails is not mandatory, and the amount of welding is free. However

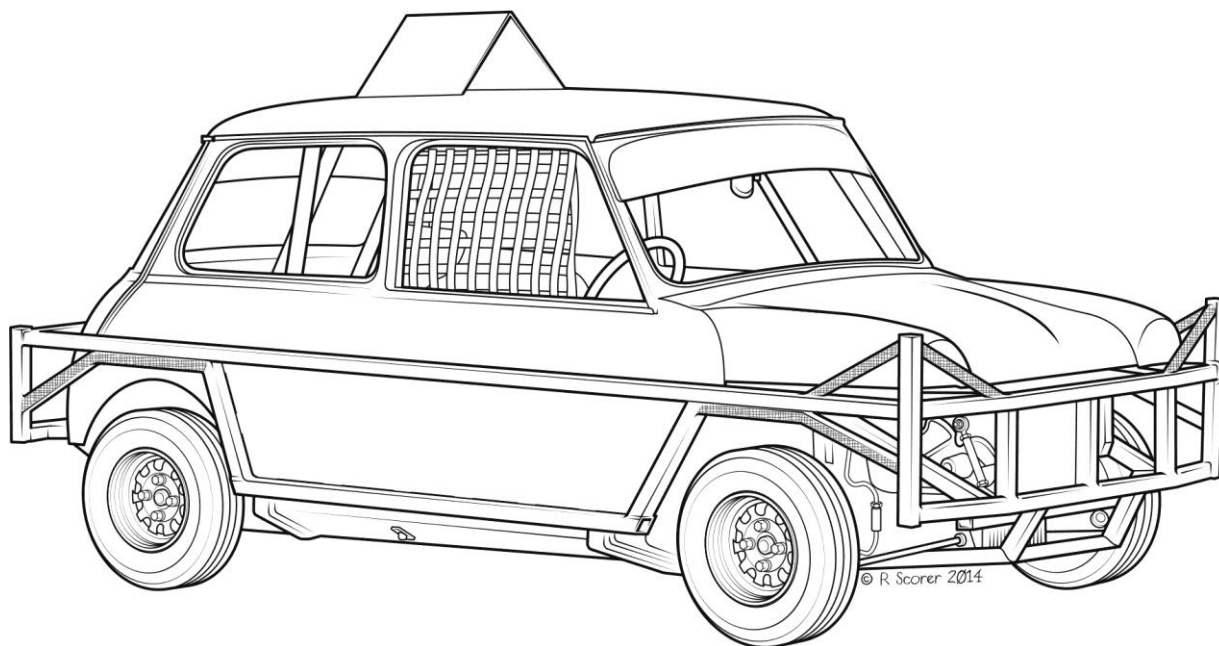

should the two rails have a gap between them, they must be joined at intervals in a ladder fashion.

- **NO EXTRA STEELWORK THAN THAT SHOWN IN THE DIAGRAMS IS PERMITTED ON THE EXTERIOR OF THE CAR.**
- Two lengths of steel SHS or RHS as noted in bullet point one above, **MUST** be fitted **COMPLETELY** underneath the car from the front bumper to the rear bumper, to which the subframes must be welded. The area between the front and rear subframes must be one continuous length on the underside of the car. Holes may be located in the floor area to connect inner steelwork to the under rails. These rails must pass completely underneath the rear sub frame before returning up to the rear bumper.
- Sump guards may be fitted but must be securely fitted in place on the car, by means of bolting or welding.

FRONT BUMPER

- The front bumper must consist of two horizontal bars, with four or five vertical uprights, and be between 230mm and 360mm in height (not included triangular extensions, see below).
- The front bumper must also have a triangular extension on both sides, and this must be braced back to the top of the side rail, but no further back than the centre of the front wheel. The maximum size steel required for this is stated in the first paragraph of rule 5. However the minimum steel permitted for the triangular extension is 25mm SHS or equivalent tube.
- It is permitted to shorten the side rail by up to a maximum of 150mm from the line of the front bumper, to taper the front bumper. It is not permitted to taper the side rail to the bumper.
- The bumper must have a minimum of 770mm straight section centrally across the front of the car before any taper to the side rails. The taper must be straight not curved. It is permitted to taper the lower horizontal bumper rail up at the ends, as long as the minimum of 770mm straight section is achieved and the bumper meets the 230mm minimum depth.
- Diagonal bars from the side rail to the front bumper are permitted to the specification noted in Bullet 1/Rule 5.
- No steel is permitted to be placed back to back in a horizontal plane on the front bumper. There must be a minimum gap of 100mm before another length of SHS or RHS is placed behind the bumper.

REAR BUMPER

- The rear bumper must consist of two horizontal bars, with four or five vertical uprights.
- The rear bumper must be between 230mm and 360mm in height.
- It is permitted to shorten the side rail by up to a maximum of 150mm from the line of the rear bumper, to taper the rear bumper. However the bumper must have a minimum of 770mm straight section centrally across the rear of the car before any taper to the side rails. It is not permitted to taper the side rail.

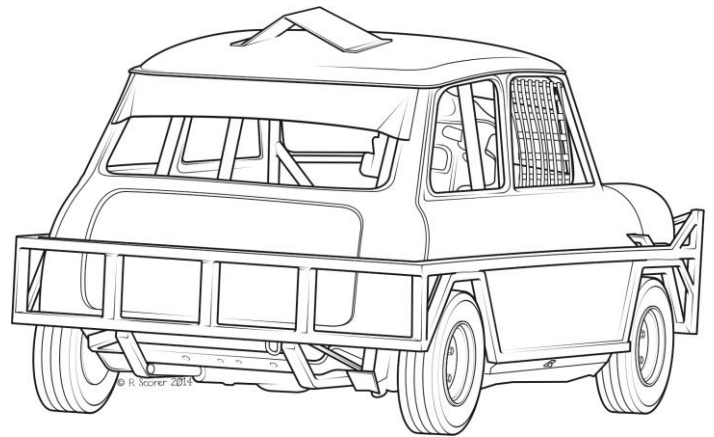

SUBFRAMES

- Both subframes MUST be mounted in their original position and as manufactured. The subframes must retain their original dimensions, such as width and angle of location in the bodyshell.
- The rear subframe must be mounted as per manufacture, retaining all components (see images). However it is permitted to add steel plate/angle etc to reinforce or repair the heelboard where the rear subframe is mounted. Additionally, you may use uprated bolts to attach the trunnion to the bodywork.
- It is not permitted to mount the rear radius arm direct to the steel work.
- The front sub-frame must still have the large top mounting bolts removable and be in their original position.
- Attachments may be welded to the sub-frame from which to mount the bumper.
- Engine mounts and bracing are free. With regard to engine mountings you may cut the sub-frame to accommodate a strengthened mount, but no more than 75mm each side of the original locating bolt. Additionally the engine must remain in its original position and not be lowered in any way.



6. WEIGHT

- Cars can be weighed at any time before, during or after a meeting, without the driver. The car must always achieve the minimum weight; the adding of fuel or any other liquids is not allowed to achieve this minimum weight, which is 720 kg. Racing weight must be achieved without the use of ballast.
- If the car is checked and found to be under the total permitted weight (not inside weight) this is an automatic ORCi suspension. Up to 1.0kg under = one month suspension, up to 2.0kg under = 2 months suspension. In excess of 2.0kg under = 6 month suspension.
- The right hand driver's side weight must be a maximum of 53.0%, at any time – this will be weighed without the driver in the car.

- If the car is over the 53.0%, but under 53.5% on the first offence the driver will lose all points/places gained on the day.
- If the car is found to be over 53.0% but under 53.5% on a second occasion (during a calendar year) the driver will receive a one month suspension and loaded immediately with loss of any points gained.
- Any car found over 53.5% on its first check will receive an automatic one month ban, and loaded immediately with loss of any points gained on the day.
- If a car is found over 53.5% on a second occasion (during a calendar year) the penalty will as a minimum be doubled, or possibly carry a longer suspension.

7. ENGINE, GEARBOX & DIFFERENTIAL

GENERAL

- All parts must remain as standard/UK manufactured to a 998cc engine either 99H or A+.
- **No competition, sports, performance, Cooper or Cooper S parts are permitted unless expressly permitted within these specifications.**
- The only exceptions are those noted below, **if it is not noted below then it is not permitted for use. Unless a rule explicitly states an action can be taken, a modification made, or replacement part sourced/manufactured, then such actions/modifications/replacements are NOT permitted.**
- You must not lighten, balance or stress relieve the pistons, con rods, crank shaft or flywheel. Only the standard factory balancing is permitted.
- All oil ways and galleries must remain unmodified with the exception of those noted in the remainder of Rule 4.
- A 50mm hole must be machined in the engine end cover in a convenient location for checking the flywheel.
- The repair of alloy casings is permitted, but this is only to add material and not remove and is intended to bring the casing back to standard.

ENGINE BLOCK

- The only codes permitted for the engine/block are those for 998cc 99H or A+.
- The original bore size is 64.59mm with 1.5mm oversize allowed. The original stroke size is 76.2mm.
- Pistons must be standard 998cc replacement type (3 ring or 4 ring type permitted), with all rings in place. No machining of pistons allowed.
- Only standard replacement rings are allowed (No competition or total seal rings allowed).
- The block may be surface ground, but the piston must be level or down the bore.
- The block may be rebored or sleeved back to standard.
- No other alteration allowed.
- It is permitted to enlarge either the oilway on the shell or the oilway on the block nearest the oil pump fitment, but not both.
- The securing of core plugs by means of a secondary fixing is permitted.
- It is permitted to blank off and remove the manual fuel pump. The blanking plate must be made of steel and not aluminium. This must remain as a blanking plate only, and not a breather.
- A non-original/aftermarket oil dipstick is permitted.

TIMING/IGNITION

- The only coil permitted is that fitted as standard to the engine, with the following exceptions:
 - Lucas Sports Coil (ref DLB105) or InterMotor Sports Coil 11105
- Rotor arms are free. These may be secured using silicone.
- Competition/sports type leads are not permitted. A secondary fixing i.e. cable tie, silicone is permitted.
- Standard timing chain and tensioner must be used. No vernier pulleys allowed.
- Off-set woodruff keys are permitted.
- Only standard form 998cc Lucas 45D, 59D, Ducellier distributors are permitted. The following exceptions apply: the advance may be altered and base plate locked. Base plate/**points/condensor maybe interchanged.**
- No electronic ignition systems are permitted.
- Spark plugs are free but must be of a single electrode type.
- The fitment of a guard over the distributor and/or coil is permitted to protect them from the elements. This must be made from rubber, Perspex or aluminium (no steel).

CYLINDER HEAD INC. VALVES

- The cylinder head must be a standard BMC/BL/Rover ~~850cc~~ or 998cc casting stamped CAM4810.
- The cylinder head may be surface ground to a minimum thickness measured between the top and bottom machined faces of 2,700 thou.
- Valves must be standard or replacement for the cylinder head noted above, with a standard length and standard valve head size of 27.89 inlet, and 25.53 exhaust.

- The only valve seat angles permitted are either the standard 45° or three angle valve seats to the following specifications, but there must be no machining or fettling past the valve seat on the valve or the head.

Three-angle Valve Seat Procedure (note: seat only not the valve)

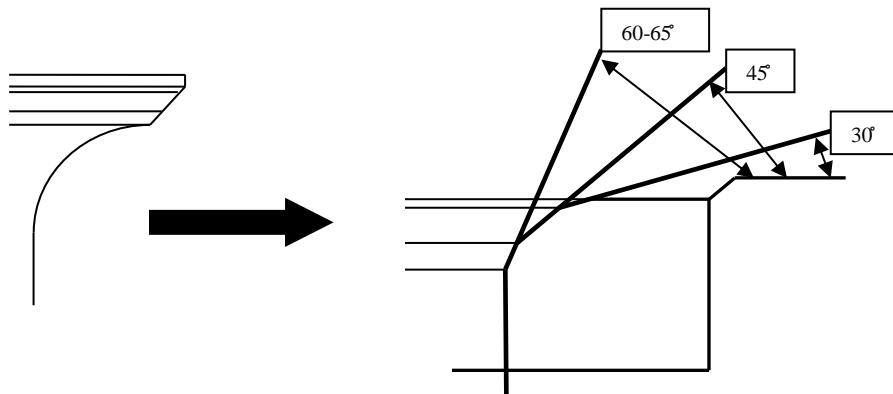

- Standard valve spring top and collets must be retained.
- Any single valve spring that fits without the need for machining may be used.
- Valve guides may be replaced or reconditioned using a thin wall bronze sleeve in existing guide, but must still occupy the original position.
- The combustion chambers and ports **must** not be modified and must not have any material added or removed. They must retain their original cast surface.
- Replacement valve inserts/seats may be fitted, but must be level with the bottom of the combustion chamber. Inserts must not be fitted that enlarge the port orifice. Inserts must return the cylinder head to its original port diameter. However, earlier CAM4810 Cylinder Heads without unleaded valve seats fitted, may fit unleaded seats using the same procedure noted above and must be of the same dimensions as originally fitted by British Leyland.
- Only the standard non-competition, replacement copper or composite gasket allowed. Thickness details to be provided.
- Cam followers, push rods and rockers must be standard Mini 998. However, a maximum of two holes per cam follower are permitted for oil relief. These may be drilled at any angle.
- Any camshaft may be used that fits without additional modification to the engine or components.
- Rocker Gear: All factory types will be accepted with a ratio of 1.25 to 1.
- Aluminium rocker covers are permitted.
- External repair by means of welding is permitted if the casting is failing where a stud is located. Any repair internally is not permitted.
- Water bypass outlet on cylinder head may be blanked off.

CARBURETTOR/INLET MANIFOLD/AIR FILTER

- Only the standard Mini 1000 1½" HS4 carburettor, with the single outlet exhaust manifold, number 12G787 without brake servo outlet is allowed.
- These items must remain in their standard form. No machining is permitted, to include, but not exclusively, smoothing, mechanical cleaning shot blasting (or any form of blasting) fettling, any of the flow areas i.e. carburettor, cast carburettor down pipe (as circled in diagram), carburettor insulating block, restrictor plate or inlet manifold.
- "Reconditioned" Inlet Manifolds which have been bead blasted are not permitted.
- A standard BMC/Leyland aluminium carb to manifold spacer plate must be fitted. It must retain the original casting marks internally and externally. No aftermarket plates permitted. This item must remain standard as per manufacture.
- The choke mechanism must be in place on the carburettor.
- The only cleaning permitted is with non-hazardous water based parts wash/degreaser or liquid such as petrol, diesel or carb cleaner. No acid dipping treatment of any kind, or dipping with electrolysis is permitted.
- No casting profile/marks are permitted to be removed.
- The carburettor must be used with the restrictor plate provided by your ORCi Promoter (**stamped ORC15**). The plate must be fitted with the ORCi label at the top and fitted to the manifold with the holes provided.
- The restrictor plate must be fitted between the sandwich plate and the inlet manifold. Once fitted, you may modify the corners to allow throttle linkage clearance. **Drivers are to be reminded that any tampering with the supplied restrictor plate will automatically attract a 12 month ORCi racing ban.**
- Jets and needles are free. No quick lift chamfers.

- It is permitted to blank off the external pipe for the vacuum advance/retard and the crankcase purge hose, by whatever means. No other holes are permitted to be blanked off.
- The original air cleaner and filter/element maybe removed. These items are shown in the lower photo on the right. Additionally, the cast carburettor down pipe as noted by the circle in the diagram maybe removed. Should the carburettor down pipe be retained it must remain completely in standard form, with no machining, i.e. the centre stud for mounting the original air cleaner housing must be retained (as shown in the diagram).
- The only permitted air filters are the standard direct replacement part for the Mini 1000 pancake style filter or the flat 1" thick aftermarket replacement foam/chrome filter. No K&N filters allowed.
- No ram/force air components are permitted anywhere within/inside/between carburettor/air cleaner housing/air filter/carburettor down pipe/carburettor insulation block, this includes, but not exclusively reducers, trumpets, cones, or inserts.
- If a standard pancake air filter is used the (hot) air intake must be removed completely as shown below.

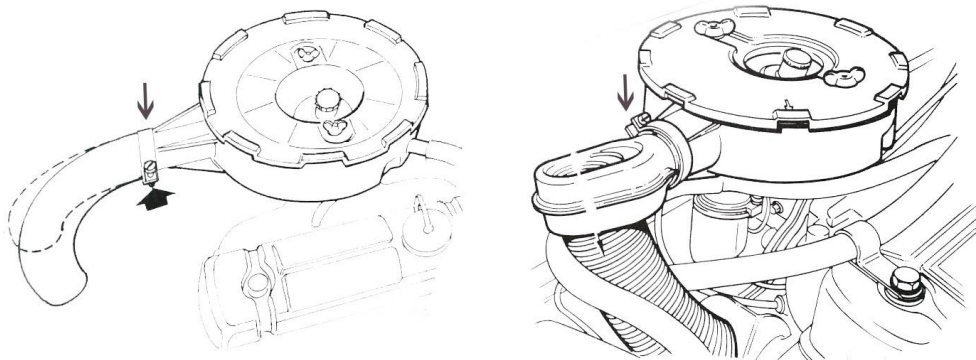
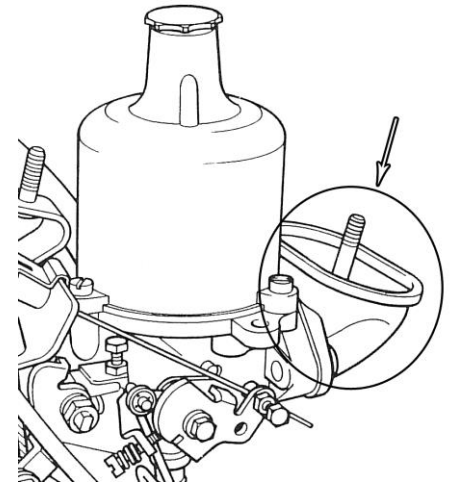

RADIATOR

- The radiator must be mounted in its original position within the engine compartment.
- The radiator may be either standard production type or aftermarket aluminium as long as it retains the same volume of water as that originally fitted. The standard Mini cowling must be retained.
- All hoses are free.

GEARBOX/DIFFERENTIAL/DRIVE SHAFTS

- The only gearbox permitted for use is the standard BMC/BL 998cc A+ type identification number DAM 5626.
- **Interchanging of internal parts is not permitted.**
- ALL gears must be as manufactured for the 998cc DAM 5626 gearbox.
- GEARBOX must be standard 998 A+ type and have 4 forward and 1 reverse gear (all working).
- Gearbox tooth count:

GEAR	LAY GEAR	GEAR
1st	15	31
2nd	21	26
3rd	26	21
4th	30	17

- Final drive ratio 3.44:1 = 18 tooth pinion and 62 tooth crown wheel.
- Crankshaft gear 29 teeth, Idler 37 teeth and 1st motion gear 29 teeth.
- All diffs must be unlocked, no limited slip or power lock types.
- Only a standard gearstick is permitted. Quick change or remote gear change is not permitted. It is permitted to bend or lengthen the standard gearstick.
- It is permitted to lengthen both drive shaft retaining cups by up to 30mm.
- All drive shafts, CV joints and offset sphere joints must be connected as standard. No secondary fixing permitted, i.e. welding.

- The speedo drive housing must remain as standard. However, the speedo cable and drive maybe disconnected/removed. It is permitted to add a mild steel or aluminium plate only for the purposes of engine bracing/mounting or preventing the loss of oil between the speedo housing and the gearbox. To allow the fitment of a flat plate it is permitted to remove the lug from the back of the casing.

OIL PUMP/OIL FILTER/OIL BREATHER

- Oil Pumps: All three types of oil pump drive to suit the cam are permitted.
- The oil pickup pipe may be repositioned.
- No oil coolers or remote oil filter allowed. Compact oil filters are allowed.
- The engine must be fitted with a metal catch tank of 1 litre minimum capacity connected to the engine breather system. This must be fitted under the bonnet and be in working order.
- The only engine breather permitted is the standard breather from the tappet plate cover as manufactured. No other breathers/pipes permitted.

8. WHEELS & TYRES

- Any standard mass produced 10" or 12" manufacturers steel wheel, to a maximum of 5" width may be used. No wheel spacers allowed. No wheel or tyre is permitted to sit outside the steelwork with the exception of NSF.
- Tyres and wheels may be non-symmetrical on the front, i.e. 10" or 12" on either side. Only 10" wheels may be used on the rear.
- Uprated wheel studs may be used, and it is permitted to drill out the drive flange and drums for this purpose.
- Any road going tyre up to a maximum width of 6.2 or 165 may be used, with the exception of the following:
 - Competition tyres, re-grooved, Town & Country, remould tyres, winter pattern, M&S and ATV tyres.
 - Avon CR6ZZ, Dunlop Formula R, Kingpin Sportway Supagrip, Yokohama A032R, Yokohama A038R, and Yokohama A048R irrespective of suffix.
- All identification marks must remain on tyres. Tyre flaps and tyre softener are not permitted.
- All tyres must be inflated with compressed air only no nitrogen.

9. SUSPENSION - FRONT

- Suspension components must remain standard unless specifically stated below.
- All suspension parts must be mounted in the original position and must not be attached to any additional steel work. All cars must have suspension movement up and down.
- Suspension cones, trumpets and ball sockets must be fitted unmodified. Rubber cones must have original markings on them, stating either Moulton or Dunlop. Adjustment of ride height may be achieved by adding washers. Alternatively, adjustable hi-lo kits maybe used in conjunction with rubber cones. These must be commercially available and not homemade.
- The only shock absorber permitted for use is the KYB 442001 in standard form. Manufacturers' markings must not be removed.
- On the NSF you may lengthen the track control arm to give a maximum of 4° negative camber on the NSF wheel.
- On the OSF positive camber is NOT Allowed. It is permitted to alter a standard OSF track control arm by up to 20mm to ensure the wheel has no positive camber. This must not be adjustable.
- The use of after-market threaded adjustment type track control arms is permitted (no homemade or rose joint type adjustable arms permitted).
- No rose joints or spherical bearings permitted **with the exception of steering columns as noted below.**
- To achieve the permitted wheelbase (on either side) you may modify a standard tie rod, by a maximum of 25mm only. Alternatively, an aftermarket adjustable tie rod is permitted and may remain adjustable on the car (no homemade adjustable tie rods permitted).
- Ride height will be measured on the driver's side of the car (without the driver), from the ground to the underside of the roof gutter at the 'B' pillar; it must not be less than 1170mm at any time.
- The steering rack may be lengthened on the near-side only, by up to a maximum of 20mm. Alternatively the use of a longer track rod end is permitted, however these must be mounted as standard i.e. the rod end must mount from the underside facing upward (as per picture).
- Steering racks must be mounted as standard.
- Shock absorber mounting brackets must be mounted as original.
- Bump stops must not be removed, remain in their original place and must be of the non-competition type.
- The standard Mini steering column may be modified or repositioned to suit the driver, **with the use of rose joints.** Quick release steering wheels are permitted.
- Bushes are free.

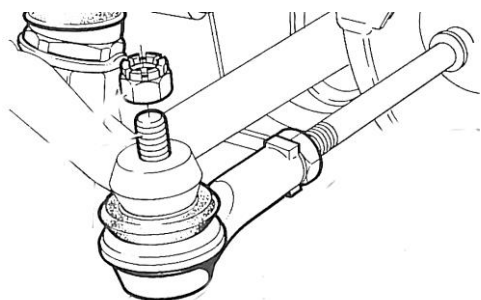

10. SUSPENSION – REAR

- Suspension components must remain standard (including mountings) unless specifically stated below.
- The only permitted shock absorber is the KYB 442002. Manufacturers' markings must not be removed.
- The rear suspension must always be set within the manufacturers tolerances.
- ***During 2021 measurements will be taken from the grease nipple on the radius arm to the ground and roof gutter on both sides of the car to determine the correct ride height.***
- Camber on the rear wheels may be achieved by elongating the mounting holes on the radius arm bracket.
- This is intended purely to achieve camber on the wheels up to a maximum of 2° positive or negative, and not for the purposes of creating rear wheel steer etc.
- Should it be deemed that this rule is being used for purposes other than permitted camber on the wheels, the scrutineer has the right to insist a car is altered before it races.
- Adjustment of ride height may be achieved by adding washers. Alternatively, aftermarket adjustable hi-lo kits maybe used in conjunction with rubber cones (no homemade adjusters permitted). Rubber cones must have original markings on them, stating either Moulton or Dunlop. No aftermarket cones permitted
- It is permitted to repair the radius arm brackets or use aftermarket uprated brackets up to a maximum of 6mm thick. THESE ARE NOT PERMITTED TO BE ADJUSTABLE ON THE CAR. NO HOMEMADE BRACKETS.
- Bushes are free.

11. FUEL SYSTEM & FUEL

- Fuel tanks must be steel (minimum 3mm wall) or aluminium (minimum 4mm wall) with a maximum capacity of 9 litres. These must be securely mounted inside the boot area and completely on top of the steelwork.
- All tank filler caps must be metal and screw type fixing.
- A metal firewall must be in place around the fuel tank.
- The face nearest the driver, the two sides and top (deflecting to the rear) must be protected around the tank with a firewall. Fuel tanks that are completely enclosed and are not visible from the rear window aperture are not permitted unless access can be achieved via the rear light apertures.
- Where additional internal panelling is used, these must be EASILY detachable to allow full visible access. These must via quick release fixings and not tex screws or nuts/bolts.
- Petrol pipes must be of metal, metal covered or specific rubber braided fuel hose and have a shut off tap within easy reach of the driver. Reminder that rubber connecting hoses on fuel lines are not permitted
- All tanks must be fitted with a breather system, which prevents spillage if a car is inverted. A non-return valve is compulsory in the breather pipe.
- All petrol pick up pipes must draw through a stand pipe from the top of the fuel tank.
- Fuel lines must be clipped securely, and routed away from electrics i.e. if a fuel line runs along the inside edge of the chassis rail, you may run the electrics along with outside edge of the rail, as a minimum.
- Electric fuel pumps can be used in place of the standard manual pump, but they must be situated in the boot area behind the fire wall. Holes must be drilled at the lowest point under the tank to allow spilled fuel to drain.
- The use of in-line fuel pressure regulators is allowed.
- For the full fuel specification please see separate sheet.

12. BATTERIES & ELECTRICAL

- Batteries must be securely clamped in place behind the driver with a leak proof material to prevent spillage of corrosive liquid. Gel type batteries are permitted.
- An electrical cut/off switch must be fitted to the R/N/S corner of the car.
- If a car is fitted with an electric fuel pump, a switch must also be within easy reach of the driver.
- Self-starter motors must be fitted and in working order at all times.

13. BRAKES

- Drum brakes only are permitted, and must be effective and working on all four wheels.
- The standard Mini master cylinder only is permitted, with either the single line or twin line system, fitted as per manufacture.
- Brakes shoes are free. Handbrake components maybe removed.
- Brake drums maybe machined for the purposes of correcting deviations only. It is permitted to drill out the stud holes to accommodate an M12 wheel stud.
- It is permitted to use the standard Mini sparcered drum on the rear only, provided they are fitted to both sides.
- Pedal boxes must remain standard; however it is permitted to remove external bracketry. The brake and clutch pedals must remain as original, slide plates maybe be attached on the pedal up to a maximum of 5mm thick, but pedal extensions are permitted for young drivers.

14. TRANSPONDERS/RACECEIVERS

- An AMB transponder as noted below for lap scoring is mandatory and must be working at all times.

- MyLaps/AMB – Tran-X 260 DP (Direct-Powered)
- MyLaps/AMB – Tran-X 260 (Rechargeable)
- MyLaps/AMB – Tran-X 160 DP (Direct-Powered)
- MyLaps/AMB – Tran-X 160 (Rechargeable)
- MyLaps – X2 Car Transponder (Rechargeable)
- MyLaps – X2 Car Transponder (Direct-Powered)
 - Note: The subscription for the latest X2 range of transponders MUST be activated, and the transponder enabled before it can be used on track.
- It must be fitted 1.8 metres back from the front most position of the car. A hole of at approximately 150mm square is required in the floor, with the transponder fitted vertically, just above the hole.
- In the event of a dispute with the transponder result, the Steward of the meeting will make the final decision, however, if the driver is found to have fitted the transponder further forward than the required 1.8 metres, then the driver will be excluded from the meeting.
- AMB transponders are not used at Crimond Raceway (the system won't work there due to local radio interference). The Identisport type is used and can be hired on race days at Crimond. These should be mounted on the bar that runs down the centre of the windscreen aperture.
- A Raceceiver for the Steward to communicate with the driver is mandatory.

15. SEATS

- Aluminium, steel or fibreglass competition seats are mandatory, and must be securely fitted as per manufacturer's recommendations.
- The seat must be mounted on mild steel SHS/RHS/CHS which is welded into the constructional steelwork of the car. Seats are not permitted to be mounted directly off the floor pan.
- The back of the seat must be adequately supported and provide a strong head restraint. otherwise this restraint must be an integral part of the roll cage.
- Driver's seat may be moved up to 75mm from original position towards the middle of the car.
- The rear of the seat, below the harness apertures must be adequately supported using mild steel SHS/RHS/CHS connected directly to the internal steelwork of the car.

16. SIGN WRITING

- Driver's name must be painted on a sun visor bolted or welded to the top of the windscreen aperture.
- Official racing numbers must be displayed on both sides of the car (door area) and on a roof fin plate visible entirely above the gutter line. The roof fin plate must be fixed to the roof/gutter line, and not mounted on brackets or framework off the roof i.e. no aerofoils.
 - Numbers must be of professional appearance, painted black on a minimum white background of 50mm.
 - Regulation side numbers must be 275mm high in 50mm strokes.
 - Regulation fin numbers must be 230mm high in 40mm strokes.
- No offensive, or childish signwriting is permitted.
- The following signwriting ONLY may be painted on the roof: registered racing number, roof grade championship title and track championship title.

17. ROOF COLOURS/GRADING

- When notified of their grading, drivers must paint the entire roof of their car in their appropriate colour, White, Yellow, Blue or Red, down to the gutter line. No superstar grade. The current points leader must paint their roof with a silver stripe.
- The following championship roof grades only are permitted:

National	Gold Stripe (300mm wide)	British	Black/White Chequered
English	St. George's Cross	ORC	Orange/White Chequered
Scottish	St. Andrew's Cross	Points Champions	Silver

- The race grid must line up as shown below, with a grade gap between each group.

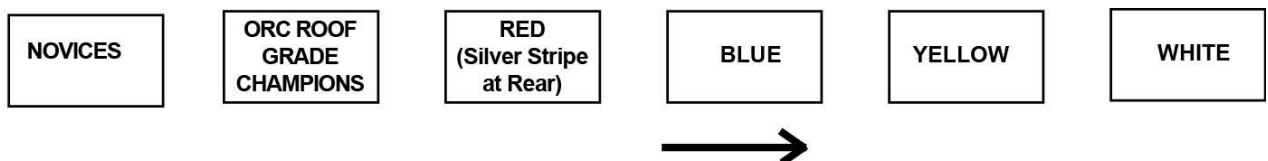

- A driver winning a race must start the remaining races, at that meeting, from the rear of their grade. This is the driver's responsibility. Drivers will be docked two places for each position out of place taken at the start.

- Grading points must take account of a driver's points scored not only with their licencing promotion, but also at other promotions.

18. EXHAUSTS

- Exhaust system must be a complete standard Mini 1000 system, which terminates to the passenger side as original. This can be either a one box or two box system. The standard replacement two piece system supplied by Mini Spares is permitted (item number GEX106).
- This must be a standard bore exhaust pipe max OD of pipe is 1¼" (32mm).
- The rear box must be located within the confines of the rear sub frame as standard and must also have a minimum of a 50mm length tail pipe remaining on the rear silencer box.
- The lagging of exhaust systems is not permitted.
- **Scrutineer's have the right to check and remove any exhaust system that may appear to have internal components removed.**

19. ORCi Driver Safety Equipment Specification Regulations

- The "Driver Safety Equipment Specification Regulations" are a common set of regulations, produced by the ORCi, governing the safety equipment used by drivers, and applicable to all ORCi sanctioned formulas.
- These regulations are located in the "Technical" section of the ORCi website where they can be accessed by anyone, and managed in a controlled fashion to ensure integrity and consistency across formulas.
- Drivers should regularly consult the ORCi website for the latest applicable regulations and updates:
 - ORCi Website Technical Section: <http://www.orci.co.uk/Content/Technical>
 - ORCi Website Home-page: <http://www.orci.co.uk/Home>
 - Follow the ORCi on Social Media: Facebook - @OvalRacingCouncilInternational
 - Twitter - @orc_int

20. GENERAL RULES OF RACING

- Each driver is only permitted one car per meeting, and each car is only permitted one driver per meeting. **A responsible adult must be present at each race meeting with a Ministox driver and must adhere to ORCi Safeguarding Policy in that they must not be under influence of alcohol or other substances.**
- Drivers may only use limited force to push a car off its line, or spin a car towards the infield. The following are not allowed: deliberate or forceful fencing, side swiping, pushing a car or cars with such force that is deemed to be excessive, or spinning a car towards the racing barrier. Such actions will at the Steward's discretion see driver's disqualified from a race as a minimum. A driver "not racing to win" will be subject to disciplinary action by the Steward. Should a driver be "loaded-up" from a race meeting, they will lose all points gained at that race meeting.
- New drivers must display a black cross on a white background on the rear of the car, sufficiently sized for other drivers to see. This will mean that other drivers must not make contact with them, and that they will not be allowed to make contact with other competitors.
- Perpetual trophies remain the property of the staging promotion, and must be returned on the anniversary of the said race or when requested. Failure to do so will result in the driver being suspended until the trophy is returned.

Please note that all of the above rules are subject to change in respect of Health & Safety requirements.

REVISED RULES FOR 2021 IN *RED/BOLD/ITALIC* PRINT

ITEMS MARKED ~~STRIKETHROUGH~~ ARE NO LONGER ALLOWED

2021 ORCi Ministox Technical Specifications, Issue v1.3 - Dated 12 June 2021.

These rules are valid from *1st July 2021*.

© Ministox Association (part of the Oval Racing Council International)

This document or any part therein must not be reproduced without prior written permission from the Oval Racing Council International