



2022 CC Rods Specifications

VIOLATIONS

When referring to the engine, gearbox, differential, mechanical or construction, rules and regulations the principle will always be - Unless permission is specifically granted to make modifications, or any variation, nothing may be done to alter or change in any way standard parts.

Unless these rules state you can do it then **YOU CANNOT DO IT.** *The promotion reserves the right to amend these rules at any time.*

Cars, Engines and Fuel will be checked on a random basis. Violations will result in an immediate suspension of all racing facilities and any refusal will also result in an immediate suspension.

Drivers are reminded that scrutineer checks can be carried out at any time and most certainly at official championships. If parts are suspected of being illegal make sure you leave them with the promotion if you do not agree or if you refuse it will automatically make the part or parts illegal. It is the responsibility of the driver to prove to the promotion that the part is legal by the way of written proof of where the part originated. This must be done within 7 days; otherwise the part (s) in question will be deemed to be illegal and will result in immediate suspension from racing and referral for disciplinary action.

CAR CONSTRUCTION RULES & REGULATIONS

INTRODUCTION

The formula is designed to encourage new drivers to our circuits to enjoy the atmosphere and thrills of driving on an oval without substantial financial investment or for those drivers who cannot give the commitment to compete at the very high level of all our present formulae. **CC Rods are a NON-CONTACT racing formula!**

Drivers will be graded on a monthly basis and must have a ~~minimum of an 8-inch strip from the front of the roof to the rear of the roof~~ **their roof fin** displaying their current grade. Gradings will be based on the drivers points, however, the drivers average across the season will also be considered. Any driver who wins a race will be required to start the remaining races at that meeting from the rear of their grade – should a driver win two races at the same meeting, they will automatically be upgraded for the remainder of that grading period and the next – it is the driver's responsibility to ensure that they start in the correct grid and position.

WHAT YOU NEED

A licence is required to participate, either a full licence or a day licence. Application can be obtained from Hardie Race Promotions. Participants must be aged 16 or over; Anyone under 18 must have a parent/guardian consent form completed.

CARS ELIGIBLE

Any make/model that had a BHP output of less than 120BHP as standard from the factory. Cars must weigh a minimum of 750kg and can be checked at any time with no replacing of fluids permitted.

PREPARATIONS & PAINTWORK

Remove all exterior mouldings/ headlamps/ door handles, exterior mirrors and dashboard.

Remove all glass, interior trim, door linings, floor coverings, passenger seats.

Any car arriving at the stadium with glass either fitted or loose inside the car will NOT race.

Windscreen rubbers must be completely removed. All obsolete wiring must be removed.

Tow bars must be completely removed together with spare wheel carriers.

All cars must be neatly turned out and painted at the start of the race meeting. Any driver arriving at a meeting with a car which in the scrutineer's opinion is untidy WILL NOT be permitted to race.

Cars may be de-skinned from the inner waistline down.

The drivers racing number must appear on both sides of the car and should be large and stick out clearly on the car.

A sun visor made of metal and have a depth of at least 6" may be fitted at the top of the windscreen aperture. The drivers name must appear on the sun visor. All sign work must be presentable. A roof fin is compulsory and must have your registered racing number a minimum of 9" high and 1" wide in black on a white background on both sides.

WEIGHT

Cars must weigh a minimum of **750kg** and can be checked at any time with no replacing of fluids permitted. **A maximum of 20kg** ballast must be secured to the ~~floor~~ **left side of the car against the inner sill** by way of bolts which are then welded in place for safety.

BODY WORK AND BUMPERS

No welding for strength. Front and back doors (driver's side only) may be seam welded for safety but boot and hatches may only be tack welded. This is defined as a 2" weld with a 6" gap before the next weld.

All holes in the front bulkhead must be filled to provide a firewall between the driver and the engine.

The panelling inside the car must be easily removed for inspection from a Scrutineer. All door and bonnets must be securely shut.

Front and rear bumpers must remain as standard but may have a 2" x 1" backing. Original bumpers **MUST** be bolted securely to the car. No bumper bars are allowed.

Bright colours for the bodywork are recommended but a tidy appearance is mandatory.

Mirrors may be fitted inside the car and may have a mirror on the driver's side.

No over welding if you need to repair a panel.

Cars may be de-skinned from the inner waistline down.

ROLL CAGE

No Alloy roll cage or part cages are allowed. The minimum steel roll cage protection you must have is one front hoop, one rear hoop, one rear hoop cross bar at shoulder height to mount seat support or a seat brace hoop as a seat support, three roof connecting bars, one dash cross bar **going across the bottom of the window aperture to a maximum of 5 inches down. Also 1 25mm od or 2 10mm od tube bars from top to bottom bar on rollcage front window.** Two D/S chicken bars plus two connecting bars, & two P/S chicken bars **plus two connecting bars**, & minimum 2 rear stay bars to the rear shock towers or floor but must terminate at least 4" from the rear panel (must be either Fig 2(b) or 2(c)). The lower bar on the drivers side (if horizontal) should be a minimum of 3" (76mm) above the sill. The roll cage hoop feet must be on four welded 23cm square plate 3mm (min.) thick, or a piece of 38 x 38 mm box section, 2.5mm minimum thickness, connecting front and rear hoop feet welded to sill or floor. This bar will not be classed as a chicken bar. All joints must be welded over 90% of the joint unless as approved RACMSA cage is used. The cage must not protrude through the bulkhead with the following exception. It is permitted to support both turrets from the roll cage with the maximum material and gauge as the roll cage, but the shock absorber must not connect to it. All bars connected to the cage must be steel. The minimum thickness of the roll cage are 1¼" OD 10swg (3mm) tube 1½" OD 12swg (2.5mm) tube 1½" x 1½" 10swg (3mm) box iron. Front Windscreen bars no more than 5" from window surround.

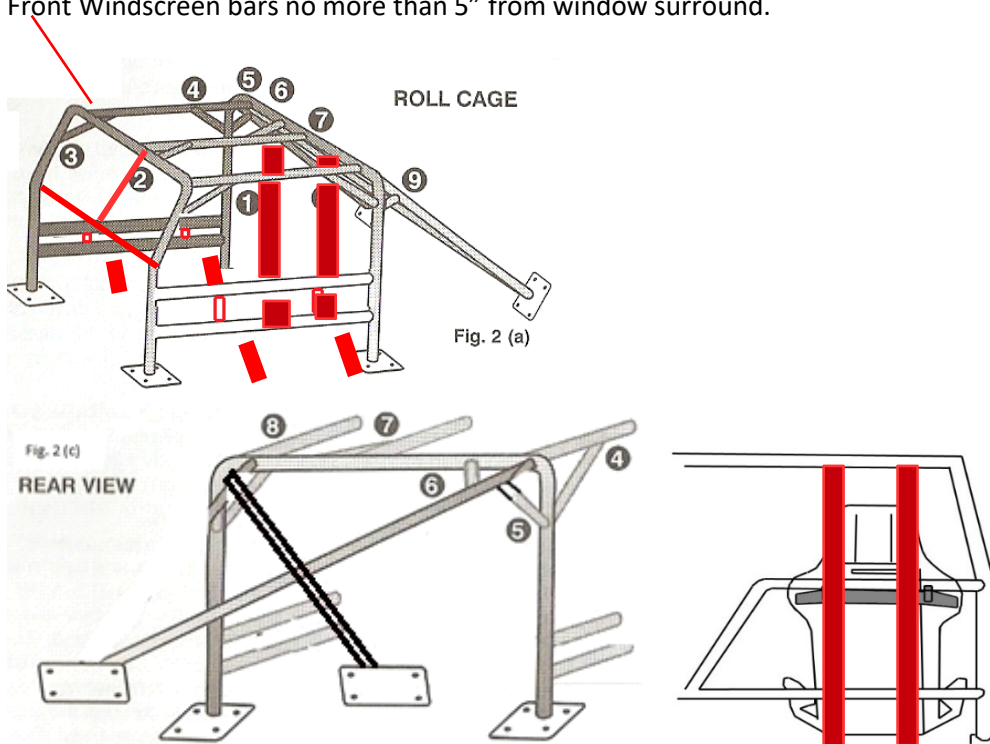

Diagram is a guideline only – ensure your car complies to the wording of the rule.

Corner gusset bars are included in the diagrams to be added as a means to add weight to the car if necessary.

A tubed sill bar will be required to be welded to the sill with the main roll cage hoop to be mounted upon the sill. Each side of the car will therefore have a sill bar and 2 chicken bars connecting the front and rear of the hoop. The drivers' side chicken bars must be one continuous piece of tube.

Welds will be checked to ensure welding is done to a required standard – if you are not a competent welder, get someone to do it.

DRIVER'S SEAT

A seat compete with a secure head restraint must be fitted, Competition seats may be used. The seat must be securely mounted at shoulder height to the cross bar or to the rollover bar

and securely bolted to the floor. When the driver is securely belted into the car ready for racing there must be a minimum 4" gap between the top of the driver's crash helmet and the roof of the car.

ENGINES/CARBURETTOR/CAMS

16v Vauxhall engines:

The Fuel injection must be removed and an inlet manifold manufactured to fit the carburetor.

This manifold rule. –

Full specification for Vauxhall 1,6 16v

All parts to be 16v with below sizes.

Bore 79.00mm –80.00mm.

Stroke 81.50mm.

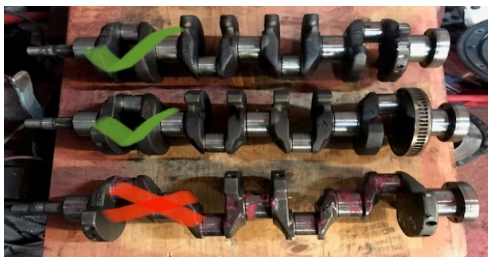

Only the crankshafts ticked green permitted twin web NO single web cranks **and must be in the original form.**

Internal engine parts must be as x16xel y16xe z16xe and to the sizes given

Cam lift

inlet 8.50mm

exhaust 8.00mm

Intake lobe width 37.00mm.

Intake lobe Height 45.50mm.

Exhaust lobe width 37.00mm.

Exhaust lobe Height 45.00mm.

Inlet valve 103.10--31.00--6mm.

Exhaust valve 102.20--27.50--6mm.

Flywheel min Weight 5kg. You can use 8v flywheel skimmed only to this weight This cannot have anyholes or slots machined into the flywheel.

Flywheel and clutch plate only may be balanced through spot machining or grinding only. No drilling completely through.

~~Block Height 198.00 min. measured from crankshaft cap seat to head gasket face.~~

Cylinder blocks may be skimmed but pistons must not protrude

Any 16v crank shaft front multi-v pulley is permitted and if running standard ECU, notch may be widened.

Cylinder head thickness measured from head gasket face to centre of cam pulleys 134.90mm min.

Aftermarket Ignition is only to be 2D TYPE

Standard ECU may use MAP sensor.

All parts to be as standard No competition parts.

Pistons to be as standard and must Not protrude.

Rocker cover breather can be modified.

Head gasket standard replacement no competition = composite or metal= Vauxhall / Elring/ victor reinz/ bga/ motive only.

Tin sump may be fitted .

Aftermarket parts permitted as long as to v/hall sizes and spec. no competition parts

The Only the head style permitted is the one ticked in green.

16v engine cam belt tensioner pulley may be locked.

The bottom pulley may be modified in order to alter the timing

Sundry. The engine must be fitted with a catch tank of 1 litre minimum capacity connected to the engine breather system, fitted in the engine compartment. **Competition air filters are permitted (NO TRUMPET, CONE OR GUIDED AIRFLOW TYPES).**

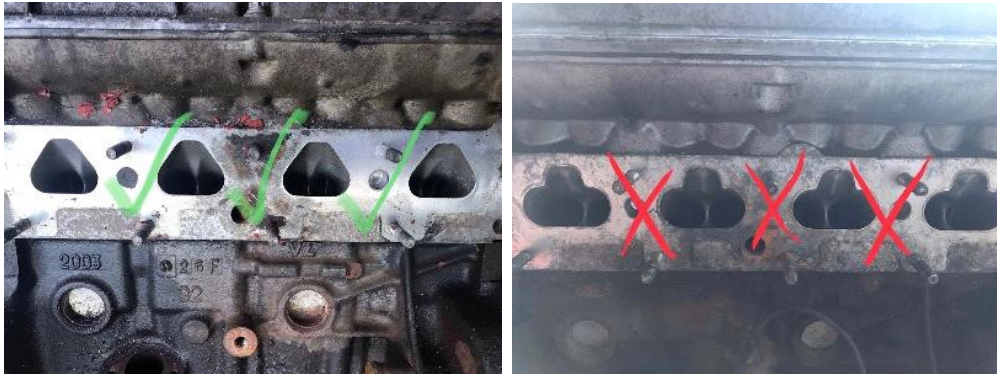

All Other Engines

All other engine manufacturers must be to original engine codes.

Engines – General

All parts to be as standard No competition parts.

Pistons to be as standard and must Not protrude.

Rocker cover breather can be modified.

Head gasket standard replacement no competition.

The bottom pulley may be modified in order to alter the timing

Aftermarket parts permitted as long as to original manufacturers sizes and spec. no competition parts

All external engine nuts & bolts can be changed except the head bolts.

External engine parts may be painted but nothing inside the engine.

Maximum 1600cc with a buy it now price of £850 by any registered driver who has the same engine model. 'Buy It Now' cannot be processed within 3 weeks of a championship event - the promotion reserve the right to impound a car and take any car to a rolling road (of the promoter's choice) should they choose to do so. A driver may also query the output of a car by paying £150 to have the car impounded and tested on a rolling road with HRP Senior Staff in attendance – the driver making the challenge will NOT be permitted to know the output of the engine. If the engine is found to be legal, the £150 fee will NOT be returned.

ALL engine components must remain standard to the specific engine used - flywheels may be lightened to a minimum of 5kg. Any makes/models of cars raced with a standard flywheel weight below 5kg must not modify the flywheel in any way. Any driver found to have broken these rules will face disciplinary action.

Fuel injection systems are permitted for use. The buy it now price does not cover the manifold and carb.

All engine parts must be standard to the engine code. Flywheels may be altered for TIMING ONLY.

Engine mounts may be modified – it is the scrutineer’s decision if these modifications are excessive and not in the spirit of the rules.

Vauxhall cars can run Weber 32/36 or pierburgh 2e or varijet carb from the vauxhall range. Main jet sizes can be enlarged. All other internal parts to be standard. Cold start dev. can be removed. Chokes may be modified to open together.

The Ford Escort 1600 16v engines may be used & can be fitted with the standard Weber.

32/36 DGV or DGVA carburettor may be used with a maximum of 26mm and a 27mm sized chokes. No polishing or re-profiling is allowed. No modifications to the carburettors body or original design. The interchanging of the carburettor top from other Weber models is not allowed. All gaskets must remain standard and original. A single original spec insulator block must be fitted between carburettor and inlet manifold, with two gaskets; approximate total thickness = 5mm. Main jets, primary and secondary jets, auxiliary venturi and emulsion tubes may be changed but must face downwards towards the butterflies. Accelerator pump jets may be changed but face downwards towards butterflies. Chokes may be modified to open together and replacement spindles may be fitted with standard screws. Cold starting devices may be removed with retaining lugs and subsequent holes blanked off. Air and fuel galleries may not be enlarged or modified, and fuel may enter on either side. Floats may not be modified or weighted, and must control the fuel flow. Needle valves may not be larger than 250, and not enlarged or modified. The power valve must be fitted in the base of the bowl, but may be sealed off, and the diaphragm may be removed. No trumpets are allowed. It is permitted to use a grub screw or similar device to fix the auxiliary venturi to the carburettor body. Top end enrichment devices may be blanked off or modified. A secondary fixing on the fuel inlet feed line is required. Any after-market four-branch manifold may be used.

INLET MANIFOLD to fit injection engine; A Driver may modify a manifold to suit and to run on the weber carb as listed in rule. These manifolds must be subject to the promoter’s approval.
Air filters are free.

FUEL

Fuel tanks must be metal or FIA approved with a maximum capacity of 4 gallons or less are permitted. These must be fitted rear of the driver but in front of the rear axle centre line, and must be at least 6” from the battery, i.e. they are no longer allowed to be fitted in the boot area. They MUST NOT BE FITTED BELOW THE REAR CHASSIS RAILS AND MUST BE FITTED ABOVE THE FLOOR INSIDE OF THE CAR, and the floor must not be cut in any way to accept the tank. All tank filler caps must be of a secure leak proof metal with a screw fitting. Petrol pipes must be of metal or metal covered and have a shut off tap within easy reach of the driver. All tanks must be fitted with a breather system which prevents spillage if a car is inverted. All petrol pick up pipes must draw through a stand pipe from the top of the fuel tank. Four 2" holes must be drilled at the lowest point under tanks to allow spilled petrol to drain. Fuel tanks must be covered by a firewall on ALL sides. Fuel regulators may be used. The fuel pump must be fitted in the rear behind the driver.

A one-way valve must be fitted to the Breather pipe.

BRAKES

Brakes must be in full working order and brake tests will be carried out. Brakes must be working on all 4 wheels.

Brake lights MUST be fitted and working.

WHEELS AND TYRES

The only tyres permitted for use from the 1st February 2022 are the Rainsport, **Toyox Proxes CR2** and SK10 tyres. These must be 15” in size.

The tyre size that is to be used is 195/50/15.

The SK10 tyre has been discontinued but will have a run out period for the duration of the 2022 season. For the Scottish Championship, the SK10 tyre will not be permitted.

Hub caps may be removed.

All balance weights must be removed. Removing rubber is permitted by buffing only. Tyre softener is NOT permitted.

EXHAUSTS

Exhausts are free but must have the original silencer box for the make of vehicle. The AX891 silencer will be the only silencer permitted for use. Maximum noise level permitted is 105 decibels – any car exceeding this level will NOT be permitted to race.

GEARBOX / AXLE

Gearbox must be as manufactured to the same range of vehicle. Axle and ratio must be as manufactured.

Locked/welded differentials are optional. Viscous diffs are not permitted for use.

RADIATORS

Any radiator may be used as long as it fits in the original position in the car. Brackets may be used to secure the radiator in place but must originate from engine block or engine mounts and must not be considered offensive. No extra cooling is permitted other than the radiator and header tank. Heater matrix must be removed. Extra rubber hosing may be used to accommodate a different radiator to the standard fitment.

BATTERY AND ELECTRICAL

Batteries must be securely clamped in place and covered with a leak proof material to prevent spillage of acid. They may be fitted under bonnet, in passenger foot-well or behind the driver, but the floor cannot be cut to accommodate them. They must be fitted at least 6" from the fuel tank. An electrical cut/off switch must be fitted to the R/N/S corner of the car. If the car is fitted with an electrical fuel pump, a switch must also be within easy reach of the driver. Self-starter motors must be fitted and in working order at all times. The use of a rev counter is permitted. A 24-volt starter system is permitted. If two batteries are fitted, then the car must have a 24-volt system. You may not use two batteries as ballast.

SUSPENSION

Must remain standard except where stated. You may do whatever you want to the near side front of the car to achieve a maximum of 10 degrees camber.

Springs are free and must be securely fixed in place to stop them falling out.

Lead is permitted on the near side front wheel and must be a maximum of 2" lead from standard.

No positive camber is permitted on the Offside Front Wheel (O/S Front Wheel must be 0% to negative). Drivers may modify the bolt holes on the strut within the confines of the strut to achieve 0% negative on the O/S if necessary.

The rear driver's side shock absorber may be changed to a shorter size that fits WITHOUT modifications.

DRIVERS

Each driver is only permitted to use 1 car per meeting. Each car must also only have 1 driver per meeting.

STEERING WHEEL

A quick release steering wheel is permitted for use.

TRANSPONDERS

Transponders are **MANDATORY** and should be working at all times – **DRIVERS MAY FORFEIT PLACES AND POINTS SHOULD A TRANSPONDER NOT BE FITTED AND WORKING**. They should be fitted 1.8 metres back from the front most position of the car. A hole of at least 6" (150mm) square is required in the floor, with the transponder fitted vertically, just below the hole. In the event of a dispute with the transponder result, the Steward of the meeting will make the final decision. Any driver found to have fitted the transponder further forward than the required 1.8 metres will be excluded from the meeting.

RACERECEIVER

All drivers **MUST** use a racereceiver.

Any driver whose racereceiver is not working when forming the grid prior to a race will not be allowed to race, unless it can be repaired before the race start.

It is strongly recommended that you carry a spare battery either in your overall pocket or taped inside your car.

GRADING

White Grade – White fin with black numbers

Yellow Grade – Yellow fin with black numbers

Blue Grade – Blue fin with white numbers

Red Grade – Red fin with white numbers

Points Champion – Silver fin with black numbers

The points champion is the only car permitted to have the roof of the car painted silver.
The current Scottish champion may display the St Andrews Cross on their roof.
The current Scottish champion should display a red fin with white numbers, and will be required to start alongside the current points champion.

SAFETY

Safety is of primary importance in motor racing. Please ensure your car is well prepared with extra attention given to the seat belts, possible fuel leakage, jagged edges on the metal work, clothing, crash helmet and when in the pit area behave responsibly.

ADDITIONAL INFORMATION

CC Rods are a formula exclusive to Hardie Race Promotions and drivers may not allow their car to race at any other circuit (irrespective of who is driving it) without prior permission from HRP.

ORCi 2022 Driver Safety Equipment Specification Regulations

The "Driver Safety Equipment Specification Regulations" are a common set of regulations, produced by the ORCi, governing the safety equipment used by drivers, and applicable to all ORCi sanctioned formulas.

These regulations are located in the "Technical" section of the ORCi website where they can be accessed by anyone, and managed in a controlled fashion to ensure integrity and consistency across formulas.

Drivers should regularly consult the ORCi website for the latest applicable regulations and updates:

ORCi Website Technical Section: <http://www.orci.co.uk/Content/Technical>

ORCi Website Home-page: <http://www.orci.co.uk/Home>

Follow the ORCi on Social Media: Facebook - [@OvalRacingCouncilInternational](#)

Updates

15/01/2022 – Engine / Carburettor wording modified

17/01/2022 – Grading information updated

19/01/2022 – Updated tyre information